

JRG

+GF+

Bedienungs- und Wartungsanleitung
Notice d'utilisation et d'entretien
Istruzioni d'uso e manutenzione
Operating and maintenance instructions

JRG Feinfilter Filtres fins JRG Filtri a maglia fine JRG JRG fine filter 1840/1846

D	2
F	11
I	21
E	31

1840

1846

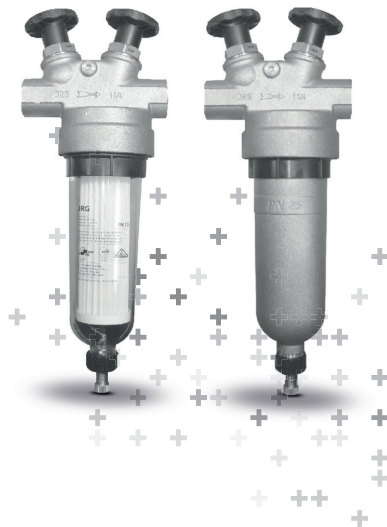

Bedienungs- und Wartungsanleitung

Bitte lesen Sie die vorliegende Bedienungs- und Wartungsanleitung aufmerksam durch. Die eingesetzten Symbole bedeuten:



Gefahr

Dieses Symbol weist auf ein hohes Verletzungsrisiko für Personen hin. Die Sicherheitshinweise müssen beachtet werden.



Warnung

Dieses Symbol weist auf eine Information hin, deren Nichtbeachtung zu umfangreichen Sachschäden führen kann. Die Sicherheitshinweise sind zu beachten.



Hinweis

Dieses Symbol weist auf eine Information hin, die wichtige Angaben hinsichtlich der Verwendung enthält. Das Nichtbefolgen kann zu Störungen führen.

Einleitung

Schwebestoffe wie Kalk, Rost, Sand usw. können aufgrund von Reparaturen, Sanierungen etc. am öffentlichen Versorgungsnetz über die Gebäude-Anschlussleitung in den JRG Feinfilter gelangen, wo sie zurückgehalten werden. Deshalb, aber auch aus hygienischen Gründen, ist der Filtereinsatz periodisch, mindestens alle 6 Monate zur reinigen oder zu ersetzen. Dabei ist auch der Filterbecher zu reinigen (nur mit Wasser). Kunststoffbecher sind auf allfällige Schäden wie Haarrisse, Kratzer, abgebrochene Teile usw. zu prüfen.



Da Trinkwasser ein Lebensmittel ist, darf der Filterbecher und das Filtergehäuse auch nur mit solchem, ohne Zusatz von Reinigungsmitteln, gereinigt werden. Dabei ist die nachfolgende Wartungsanleitung einzuhalten.



JRG Feinfilter dient lediglich dem Zurückhalten von eingespülten Schwebestoffen. Er ersetzt in keiner Weise eine gewünschte oder notwendige Wasseraufbereitung (Enthärtung, Entkeimung etc.)!

Wichtige Informationen



Klarsicht-Filterbecher sind vor Lösungs- oder Reinigungsmitteln zu schützen. Bei Installation in aggressiver Umgebung und/oder in Räumen mit unkontrollierbaren Umwelteinflüssen (wie Lösungs- oder Reinigungsmitteldämpfen etc.) muss der Klarsicht-Filterbecher entsprechend geschützt oder gegen Rotguss-Filterbecher ersetzt werden. Im Zweifelsfall beraten wir Sie gerne.



Klarsicht-Filterbecher müssen vor intensiver UV-Strahlung geschützt werden.



An JRG Feinfiltern dürfen **keine** Reparaturen ausgeführt werden.



Für die Wartung des Feinfilters ist die Wartungsanleitung einzuhalten.

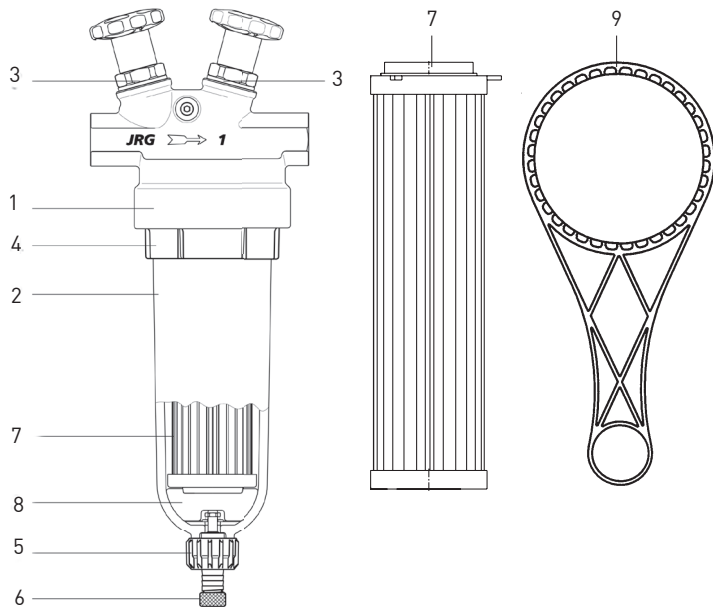

Aufbau

- 1 Filterkopf
- 2 Filterbecher
- 3 Filterventile
- 4 Gewinding
- 5 Entleerventil
- 6 Gewindekappe
- 7 Filtereinsatz
- 8 Einlegteil
- 9 Schlüssel



Wartung

An JRG Feinfiltern dürfen **keine** Reparaturen vorgenommen werden.

Ersetzen des Filtereinsatzes

 Vor dem Absperrn der Ventile einen sauberen Eimer mit Wasser füllen.

- Absperrventile vor und nach dem Feinfilter schliessen.

 Kontrollieren Sie vor dem Schliessen der Absperrventile, dass keine am Installationsnetz angeschlossenen Apparate/Maschinen in Betrieb sind.

- Filterventile **3** (im Uhrzeigersinn) schliessen. Dadurch wird die Filterumgehung geöffnet.
- Gewindekappe **6** am Schlauchnippel des Entleerventils **5** entfernen.
- Filterbecher **2** am Entleerventil **5**, durch Drehen des schwarzen Handrads (max. 1 Umdrehung im Uhrzeigersinn), entleeren.



- Gewinding **4** (im Uhrzeigersinn) mit dem Schlüssel **9**, unter gleichzeitigem Festhalten des Filterbechers **2**, lösen.
- Filtereinsatz **7** und Einlegeteil **8** aus dem Filterbecher **2** entfernen.



JRG Filtereinsätze aus Chromstahl können gereinigt werden.

- Filterbecher **2** und Einlegeteil **8** mit Wasser (ohne Zusätze) gründlich reinigen.
- O-Ring-Dichtung des Filterbechers **2** reinigen und mit **Silikonfett** nachfetten.
- Innenpartien (Dichtungsbereich) am Gehäuse **1** der Hauswasserstation reinigen, evtl. Kalkansätze entfernen.



Schnittverletzungsgefahr durch scharfkantige Innenpartien.

→ Schutzhandschuhe tragen.



- Einlegteil **8** auf den neuen Filtereinsatz **7** aufsetzen und zusammen von unten in den Filterbecher **2** einführen.



- Gewinding **4** über den Filterbecher **2** schieben.
- Filterbecher **2** bis zum Anschlag in den Filterkopf **1** einführen.
- Gewinding **4** vorsichtig am Gewinde des Filterkopfes **1** ansetzen und mit dem Schlüssel **9** leicht handsatt anziehen.



- Entleerventil **5** sowie die Be- und Entlüftungsschraube **3** schliessen.
- Gewindekappe **6** am Schlauchnippel des Entleerventils **5** handsatt festschrauben.
- Filterventile **3** langsam öffnen.



O-Ringe dürfen nur mit Silikonfett gefettet werden.



Kontrollieren Sie vor dem Öffnen des/der Absperrventils(e), dass sich alle Auslaufarmaturen in geschlossenem Zustand befinden.



Aus hygienischen Gründen darf während dem Betrieb des Filters kein Schlauch am Schlauchnippel des Entleerventils montiert sein!

Einsatzbereich

JRG Feinfilter	Nenndruck max. Betriebsdruck	Betriebstemperatur	
		mit Standard-Filtereinsatz	mit Inox Filtereinsatz 1839
1840	PN 16	max. 30°C	max. 30°C
1846	PN 25	max. 30°C	max. 70°C



Im JRG Feinfilter dürfen nur **JRG Original-Filtereinsätze** eingesetzt werden.

Ersatz-Filtereinsätze erhalten Sie bei Ihrem Sanitär-Installateur.

Filtereinsätze

Bezeichnung	Material	Feinheit	JRG Code
Standard	PES	100 µm	1838.100
NIRO	V4A	100 µm	1839.100
NIRO	V4A	1000 µm	1839.001

Andere JRG Filtereinsätze auf Anfrage.

Betriebsstörungen/Ersatzteile



Bei anhaltenden Betriebsstörungen sowie für Filterersatzteile wenden Sie sich bitte an Ihren Sanitär-Installateur.

JRG

+GF+

Notice d'utilisation et d'entretien

Filtres fins JRG 1840/1846

F 11

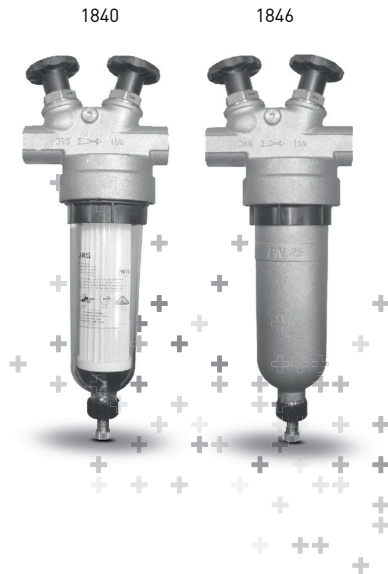

Notice d'utilisation et d'entretien

Veillez lire attentivement la présente notice d'utilisation et d'entretien.

Voici la signification des symboles utilisés:



Danger

Ce symbole met l'accent sur le risque élevé de blessure des personnes. Les consignes de sécurité doivent être respectées.



Avertissement

Ce symbole rappelle une information dont le non-respect peut entraîner des dommages considérables. Suivre les consignes de sécurité.



Remarque

Ce symbole signale une information qui comprend des indications importantes portant sur l'utilisation. Le non-respect peut se traduire par des pannes.

Introduction

Par suite de travaux de réparation, d'amélioration, etc., des particules en suspension telles que le tartre, la rouille, le sable et autres impuretés sont véhiculées par le réseau public d'alimentation en eau ainsi que par la conduite de raccordement de l'immeuble. Elles parviennent alors au filtre fin JRG qui les retient.

D'où la nécessité, pour des raisons d'hygiène aussi, de remplacer périodiquement, c'est à dire au moins tous les 6 mois, la cartouche filtrante. La cuve du filtre doit être également nettoyée (avec de l'eau uniquement). Les cuves transparentes sont à contrôler sur d'éventuels dégâts, fines fissures éraflures, parties brisées, etc.



L'eau de potable est un aliment indispensable à la vie. Ne nettoyer la cuve du filtre fin et la tête du filtre fin qu'à l'eau, sans utiliser de produits de nettoyage. Suivre les conseils énumérés dans la notice d'entretien ci-jointe.



Les filtres fins JRG servent uniquement à filtrer l'eau. Ils ne remplacent en aucun cas une installation de traitement de l'eau (déméralisation, décontamination, etc.)!

Informations importantes



Eviter tout contact de la cuve transparente de filtre fin avec des solvants et des détergents. Sur des installations dans un environnement agressif et/ou à des endroits avec des influences ambiantes non contrôlables (comme des vapeurs de dissolvant ou de produits de nettoyage etc.) la cuve transparente doit être protégée contre l'environnement, ou échangée contre une cuve en fonte rouge. Nous vous conseillons volontiers en cas d'incertitude.



Eviter toute exposition directe de la cuve transparente aux rayons ultraviolets.



N'effectuer **aucune** réparation aux filtres fins JRG.



L'entretien du filtre fin JRG doit se faire conformément aux instructions de la notice d'entretien.

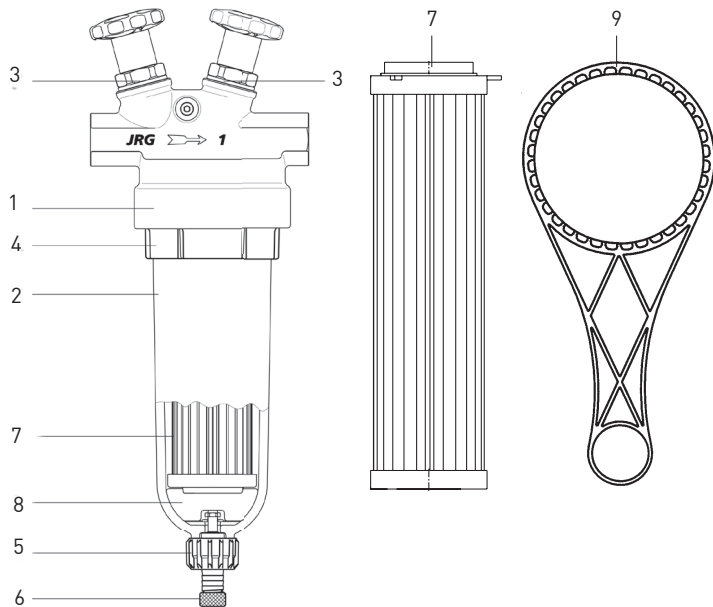

Structure

- 1 Tête de filtre fin
- 2 Cuve de filtre fin
- 3 Robinets d'arrêt
- 4 Bague filetée
- 5 Robinet de vidange
- 6 Bouchon fileté
- 7 Cartouche filtrante
- 8 Pièce d'insertion
- 9 Clé



Entretien

N'effectuez **aucune** réparation aux filtres fins JRG.

Remplacement de la cartouche filtrante



Avant de fermer les robinets d'arrêt (pour pouvoir déposer la cuve), il convient de remplir d'eau un seau propre.

- Fermer le robinet d'arrêt à l'entrée et celui à la sortie du filtre fin.



Avant de fermer les robinets d'arrêt, s'assurer que des appareils/machines branchés au réseau d'installation ne soient pas en service.

- Fermer les robinets d'arrêt **3** (en tournant dans le sens des aiguilles d'une montre). On ouvre ainsi le bypass.
- Dévisser le bouchon fileté **6** à l'embout pour tuyau, du robinet de vidange **5**.
- Vidanger la cuve **2** du filtre fin au niveau du robinet de vidange **5**, en tournant le volant noir (au max. 1 tour) dans le sens des aiguilles d'une montre.



- Dévisser la bague fileté **4** à l'aide de la clé **9**, (tourner dans le sens des aiguilles d'une montre), tout en tenant la cuve **2**.
- Sortir la cartouche filtrante **7** et la pièce d'insertion **8** de la cuve **2** de filtre fin.



Les cartouches filtrantes JRG en acier inoxydable peuvent être nettoyées et réutilisées.

- Nettoyer soigneusement à l'eau (sans additifs) la cuve **2** de filtre fin et la pièce d'insertion **8**.
- Nettoyer le joint torique de la cuve **2** de filtre fin et le graisser à la **silicone**.
- Nettoyer l'intérieur (zone d'étanchéité) du corps **1** de la station, enlever les dépôts calcaires.



Danger de coupure à cause des arêtes intérieures aiguës.

→ Porter des gants de protection.



- Placer la pièce d'insertion **8** sur la nouvelle cartouche filtrante **7** et introduire l'ensemble par le bas dans la cuve **2** du filtre fin.



- Faire coulisser la bague fileté **4** sur la cuve **2**.
- Introduire la cuve **2** jus qu'en butée dans la tête de filtre **1**.
- Placer avec précaution la bague fileté **4** sur le filetage de la tête de filtre **1**, et, à l'aide de la clé **9**, serrer sans forcer.



- Fermer le robinet de vidange **5** ainsi que la vis de purge **3**.
- Serrer le bouchon fileté **6** de l'embout pour tuyau souple, du robinet de vidange **5**.
- Ouvrir lentement le robinet d'arrêt placé à l'entrée du filtre fin.
- Ouvrir lentement le(s) robinet(s) d'arrêt, en aval du filtre fin.



Les joints O-Ring doivent être graissés seulement avec de la graisse silicone.



Avant d'ouvrir le(s) robinet(s) d'arrêt, s'assurer que les robinets d'écoulement soient fermés.



Pour des raisons d'hygiène, ne pas laisser, durant l'exploitation, de tuyau sur l'embout du robinet de vidange!

Domaine d'application

Filtres fins JRG	Pression nom. Pression de service	Température de service max.	
		avec cartouche fil. standard	avec cartouche fil. 1839 en inox
1840	PN 16	max. 30°C	max. 30°C
1846	PN 25	max. 30°C	max. 70°C



N'employer que des **cartouches filtrantes d'origine JRG** sur les filtres fins JRG.

Les cartouches filtrantes de remplacement sont livrées par votre installateur sanitaire.

Cartouches filtrantes

Désignation	Matériau	Seuil de filtr.	JRG Code
Standard	PES	100 µm	1838.100
NIRO	V4A	100 µm	1839.100
NIRO	V4A	1000 µm	1839.001

Autres cartouches filtrantes sur demande.

Pannes/Pièces de rechange



En cas de panne et pour toute pièce de rechange du filtre prière de vous adresser à votre installateur sanitaire.

JRG

+GF+

Istruzioni d'uso e manutenzione

Filtri a maglia fine JRG 1840/1846

1840

1846

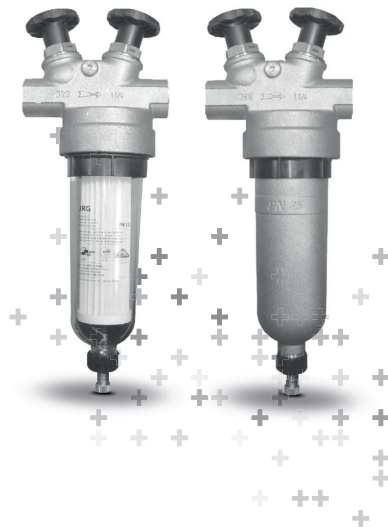

Istruzioni d'uso e di manutenzione

Vogliate avere la cortesia di leggere attentamente la presente istruzione di manutenzione.

I simboli seguenti significano:



Pericolo

Questo simbolo sta ad indicare il rischio di danni a persone. Deve essere obbligatoriamente osservato.



Attenzione

Questo simbolo indica un'informazione che l'inosservanza della quale può portare a dei grossi danni. Queste indicazioni sulla sicurezza sono da osservare attentamente.



Avvertenza

Questo simbolo informa su importanti indicazioni concernenti l'utilizzo. L'inosservanza delle quali può causare dei guasti.

Introduzione

Quando si effettuano dei lavori di riparazione, ristrutturazione od altro, alcune sostanze galleggianti come calce, ruggine, sabbia ecc. provenienti dall'acquedotto, possono arrivare, attraverso la condotta d'entrata dell'edificio, sul filtro a maglia fine JRG, che le trattiene. Per questo, motivo, ma anche per motivi igienici, è necessario pulire o sostituire l'elemento filtrante periodicamente, almeno ogni sei mesi. E' necessario pulire anche la tazza del filtro (solo con acqua). Le tazze in materiale plastico devono essere controllate per escludere la presenza di eventuali danni come crepe capillari, graffi, parti frammentate, ecc.



Poichè l'acqua potabile è un genere alimentare, la tazza e il corpo del filtro devono essere puliti solamente con acqua senza ulteriore aggiunta di detersivi. Vi preghiamo perciò di seguire attentamente le seguenti istruzioni di manutenzione.



I filtri a maglia fine servono unicamente per filtrare l'acqua. Non rimpiazza in nessun modo un trattamento d'acqua desiderato o necessario (decalcificazione, disinfezione, ecc.).

Informazioni importanti



La tazza trasparente deve essere protetta da solventi o detersivi. Installazioni in un ambiente aggressivo e/o in locali con influssi ambientali non controllabili (come solventi o vapori di detersivi ecc.) la tazza del filtro deve essere protetta o sostituita con una tazza in bronzo. In caso d'incertezza siamo a vostra disposizione per consigli in merito.



La tazza trasparente deve essere protetta da intensive irradiazioni di raggi UV.



Ai filtri a maglia fine JRG non deve essere effettuata **nessuna** riparazione.



Per la manutenzione del filtro deve essere osservata attentamente l'istruzione per la manutenzione.

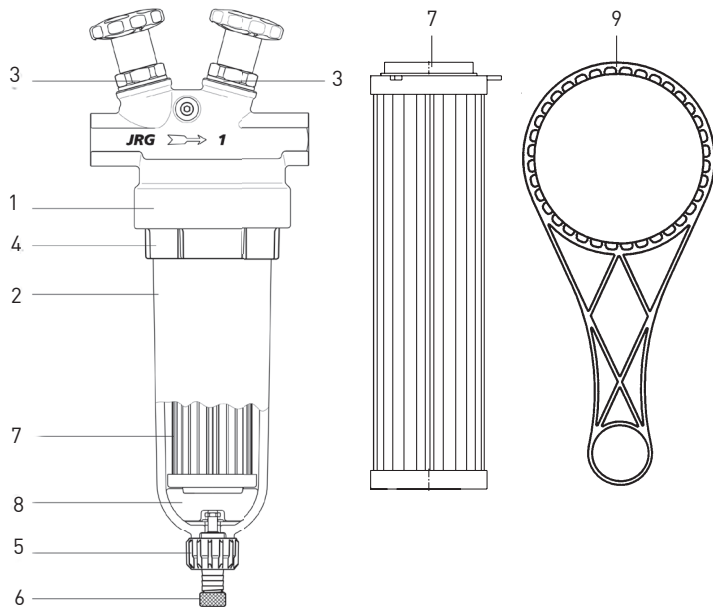

Composizione

- 1 Parte superiore
- 2 Tazza del filtro
- 3 Rubinetti del filtro
- 4 Ghiera filettata
- 5 Rubinetto di scarico
- 6 Cappa del filetto
- 7 Parte filtrante
- 8 Pezzo intermedio d'appoggio
- 9 Chiave



La manutenzione

Ai filtri a maglia fine JRG non deve essere effettuata **nessuna** riparazione.

Sostituzione dell'elemento filtrante

 Prima della chiusura dei rubinetti riempire un secchio pulito con acqua.

- Chiudere i rubinetti d'arresto prima e dopo il filtro a maglia fine JRG.

 Prima di chiudere i rubinetti d'arresto controllate che nessun apparecchio/macchina attaccato alla rete sia in esercizio.

- Chiudere i rubinetti del filtro **3** in senso orario. In questo modo si apre la deviazione del filtro.
- Togliere la cappa del filetto **6** al beccuccio del rubinetto di scarico **5**.
- Vuotare la tazza del filtro **2** con il rubinetto di scarico **5**, girando il volantino nero (max. 1 giro in senso orario).



- Allentare la ghiera filettata **4** in senso orario, con la chiave **9** tenendo fermo contemporaneamente la tazza del filtro **2**.
- Togliere l'elemento filtrante **7** e il pezzo intermedio d'appoggio **8** dalla tazza del filtro **2**.



Elementi filtranti JRG in acciaio Inox possono essere puliti.

- Pulire scrupolosamente la tazza del filtro **2** e il pezzo intermedio d'appoggio **8** con acqua (senza detersivi).
- Pulire e ingrassare con **grasso al silicone** le O-Ring della tazza del filtro **2**.
- Pulire le parti interne (guarnizioni) dell'involucro **1** da ev. depositi calcari.



Pericolo di tagliarsi, per via dei bordi affilati delle parti interne.

→ Mettere i guanti di protezione.



- Appoggiare il pezzo intermedio d'appoggio **8** sul nuovo elemento filtrante **7** e introdurli assieme dal basso nella tazza del filtro **2**.



- Infilare la ghiera filettata **4** sulla tazza del filtro **2**.
- Introdurre la tazza **2** nella parte superiore del filtro **1** fino all'appoggio.
- Montare cautamente la ghiera filettata **4** sul filetto della parte superiore del filtro **1** e tirare leggermente con la chiave **9**.



- Chiudere il rubinetto di scarico **5** come pure la vite di aerazione **3**.
- Avvitare fortemente la cappa del filetto **6** al beccuccio del rubinetto di scarico **5**.
- Aprire lentamente il rubinetto d'arresto davanti al filtro.
- Aprire lentamente il (i) rubinetto(i) d'arresto dopo il filtro a maglia fine.



Le O-Ring devono essere ingrassate solamente con pasta siliconica.



Controllare prima di aprire il (i) rubinetto (i) che tutte le rubinetterie di erogazione siano chiuse.



Quando il filtro è in esercizio per ragioni igieniche non si deve montare nessun flessibile al beccuccio del rubinetto di scarico!

Campo d'impiego

Filtro a maglia fine JRG	Pressione nom. max. Pressione d'esercizio	Temperatura d'esercizio	
		con elemento filtrante stand.	con elem. filtrante in acciaio INOX 1839
1840	PN 16	max. 30°C	max. 30°C
1846	PN 25	max. 30°C	max. 70°C



Nei filtri a maglia fine JRG devono essere inseriti solo **elementi filtranti originali JRG.**

Elementi filtranti di riserva sono ottenibili presso il vostro installatore sanitario.

Elementi filtranti

Denominazione	Materiale	Capacità filtr.	JRG Code
Standard	PES	100 µm	1838.100
NIRO	V4A	100 µm	1839.100
NIRO	V4A	1000 µm	1839.001

Altri elementi filtranti JRG su richiesta.

Disturbi di funzionamento/Pezzi di ricambio



Per disturbi di funzionamento e pezzi di ricambio del filtro rivolgetevi al vostro installatore sanitario.

Operating and maintenance instructions

JRG fine filter 1840/1846

E 31

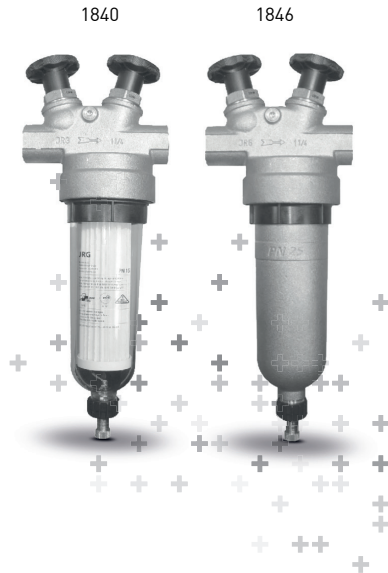

Operation and maintenance instructions

Please read carefully the operation and maintenance instructions.

The used symbols mean:



Danger

This symbol indicate a high risk of injure for persons. It must be strictly observed.



Warning

This symbol point out a information, ignoring of it can cause extensive material damage. The security information has to be observed.



Note

This symbol point out a information, which indicate important details concerning the use. Ignoring of it can result in trouble.

Introduction

Repair work etc. on the mains distribution network can result in suspended particles such as scale, rust, sand and so on passing by way of the building tee-off to the JRG fine filter, where they are retained. For this reason, but also on hygienic reasons, the filter element should be replaced or cleaned, every 6 months. During this cleaning also the filter cup must be cleaned (only with water). Plastic filter cup must be inspected if possible damages as hair crack, rabbles, broken parts and so forth arise.



Since drinking water is a food, this alone must be used for cleaning the filter cup and the filter body, with no added cleaning agents. The following maintenance instruction must be observed.



JRG fine filters are only for filtering water. They is no way replace any desired or necessary form of water treatment (softening, sterilisation, etc.)!

Important information's



Transparent filter cups should be protected against solvents or cleaning agents. If the filter is installed in an aggressive vicinity or in rooms with uncontrollable environment (solvents and/or cleaning agent vapours etc.) the transparent filter cup must be protected accordingly or replaced by a gunmetal filter cup. We will be pleased to advise you in cases of doubt.



Transparent filter cups should be protected against UV rays.



Repairs to the JRG fine filters **must** not be attempted.



For the maintenance of the fine filter, the maintenance instructions must be kept.

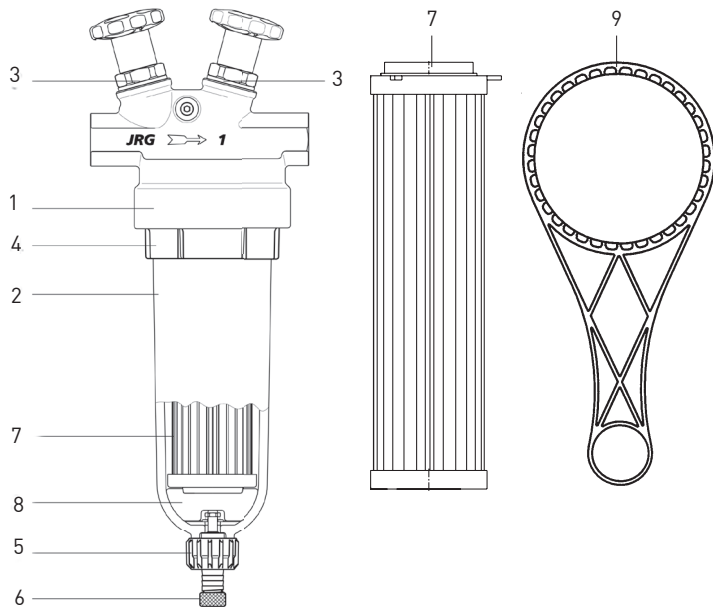

Construction

- 1 Filter head
- 2 Filter cup
- 3 Filter valves
- 4 Screw collar
- 5 Drain valve
- 6 Screw cap
- 7 Filter element
- 8 Insert
- 9 Key



Maintenance

Repairs to the JRG fine filters **must** not be attempted.

Replacement of filter element

 Before closing the valves, fill a clean bucket with water.

- Close the valves before and after the fine filter.

 Check before closing the valves if no machine or device is in operation on the same network.

- Close filter valves **3** (turning clockwise). This opens the filter bypass.
- Remove screw cap **6** from hose nipple on drain valve **5**.
- Empty the filter cup **2** by turning the black wheel on the drain valve **5** (max. 1 turn clockwise).



- Undo the screw collar **4** (turning clockwise) with key **9**, at the same time holding the filter cup **2**.
- Remove filter element **7** and insert **8** from the filter cup **2**.



JRG Filter elements made of stainless steel can be cleaned.

- Clean thorough with water (without cleaning agents) the filter cup **2** and insert **8**.
- Clean O-ring of the filter cup **2** and re-grease with **silicone** grease.
- Clean the inside of housing **1** (around the sealing surface), remove any scale deposits.



Attention! Danger of cuts due to sharp-edged inside parts.

→ Wear protective gloves.



- Insert **8** at top of new filter element **7** and install together from below in the filter cup **2**.



- Slide screw collar **4** over filter cup **2**.
- Push filter cup **2** into filter head **1** as far as it will go.
- Carefully engage screw collar **4** in thread of filter head **1** and tighten gently with key **9** until hand tight.



- Close drain valve **5** and vent screw **3**.
- Fasten crew cap **6** to hose nipple on drain valve **5** till hand tight.
- Slowly open stop valve upstream of fine filter.
- Slowly open the stop valve(s) downstream from the fine filter.



O-rings may be greased only with silicone grease.



Check before opening the valves if all taps are closed.



For hygiene reasons, no hose must be attached to the hose nipple on the drain valve while the filter is in use!

Operating range

JRG fine filter	Nominal max. operating pressure	Operating temperature	
		with standard element	with st. steel element 1839
1840	PN 16	max. 30°C	max. 30°C
1846	PN 25	max. 30°C	max. 70°C



Only **original JRG filter elements** must be used.

The filter elements are available at your plumber shop.

Filter elements

Term	Material	Mesh	JRG Code
Standard	PES	100 µm	1838.100
Stainless steel	V4A	100 µm	1839.100
Stainless steel	V4A	1000 µm	1839.001

Other fine filter elements on inquiry.

Operational problems/Spare parts



In the event of operational problems, and for filter spare parts, please ask your plumber.





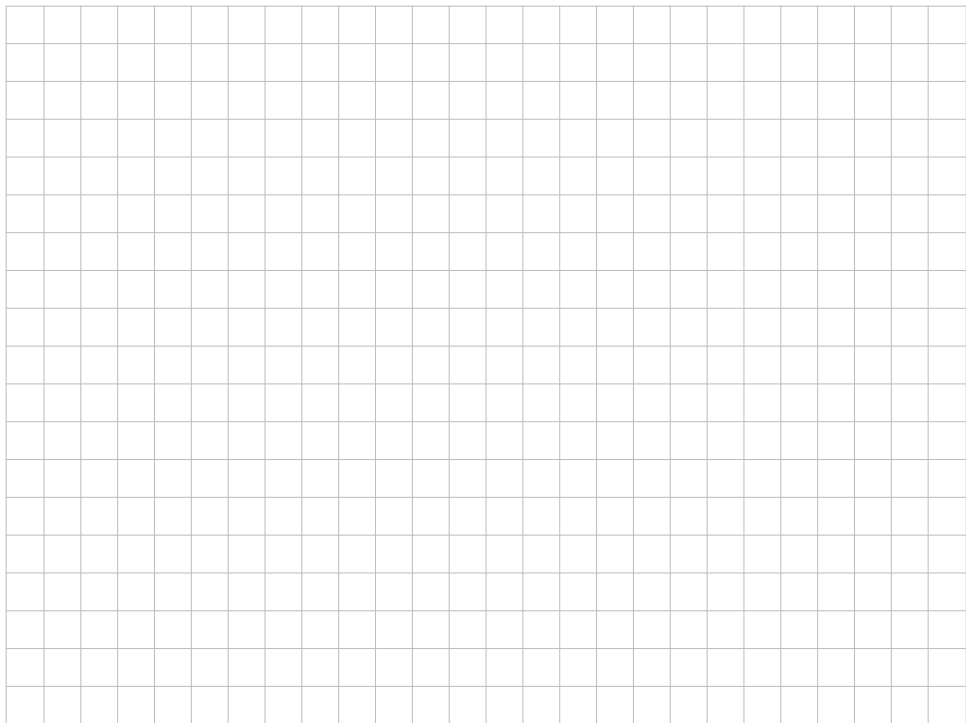

Georg Fischer JRG AG

Hauptstrasse 130, CH-4450 Sissach

Phone +41 (0)61 975 22 22, Fax +41 (0)61 975 22 00

jrg.ps@georgfischer.com

www.gfps.com

JRG

+GF+

Einbaudatum: Date de montage: Data d'installazione: Built-in date:

Ihr Installateur: Votre installateur: Il vostro installatore: Your plumber: