



Ersatzteilliste
Spare Parts List

2020-11

DUM111

DUM111 (D, GB)

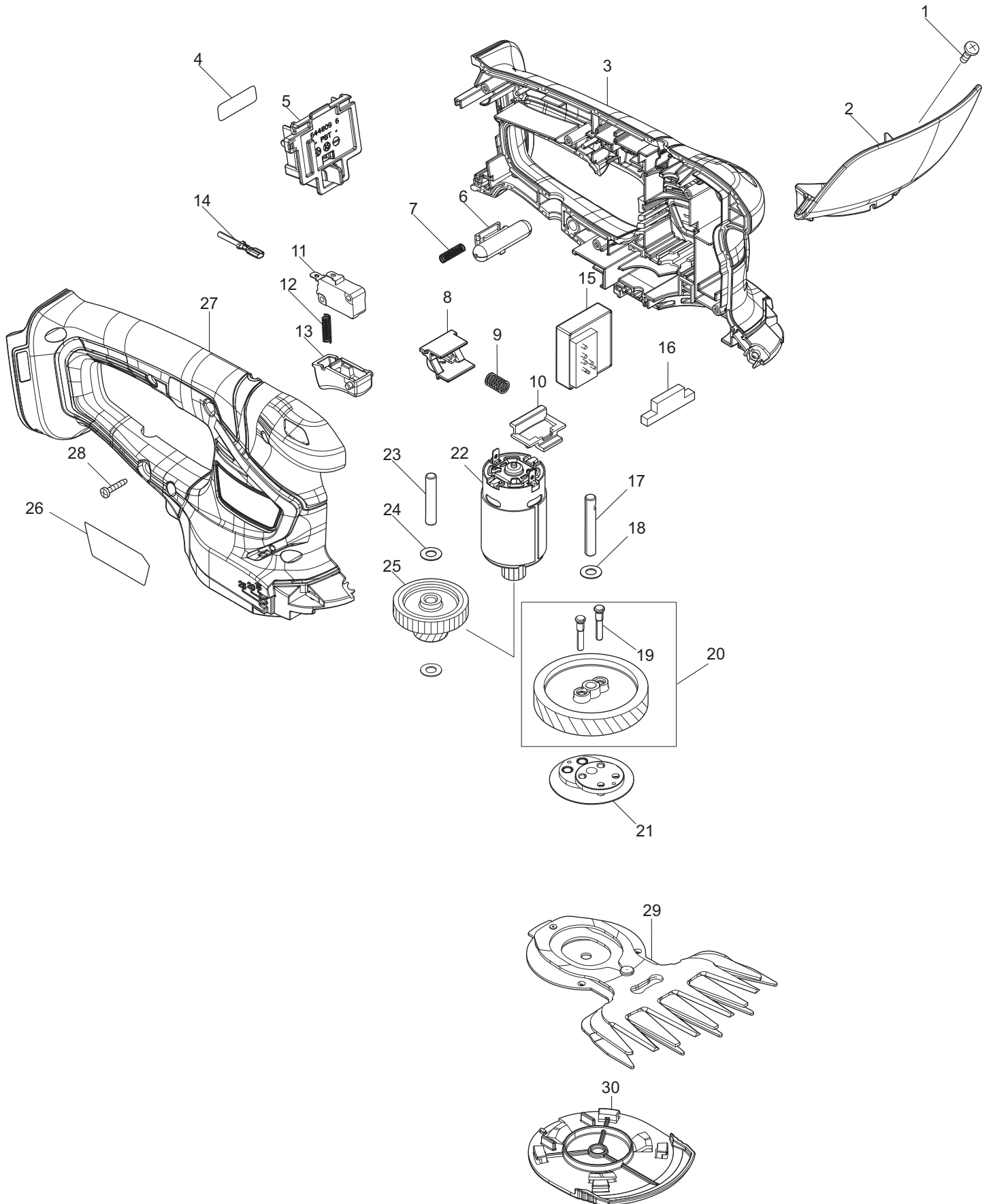

DUM111

1

DUM111
DUM111

Seite / Page	Pos.	DUM111	Teil-Nr. Part No.	Hinweise Notes	Bezeichnung	Spezifikation Specification	Description
1	1	1	915116-7		SCHRAUBE	M4x12	BINDING HEAD SCREW
1	2	1	141C31-9		HANDSCHUTZ		PROTECTOR COMPLETE
1	2	1	8030K3-8		HINWEISSCHILD		CAUTION LABEL
1	3	1	183G03-2		GEHÄUSE-SET	INC. 27	HOUSING SET COMPLETE
1	3	1	931102-0		6 KANT-MUTTER	M4	HEXAGONAL NUT
1	3	2	263005-3		GUMMISTIFT	6	RUBBER PIN
1	4	1	811957-8		SERIEN-NR.-SCHILD	DUM111	SERIAL NO. LABEL
1	5	1	644809-6		KONTAKTPLATTE		TERMINAL
1	6	1	660452438		SPERRKNOPF		LOCK OFF BUTTON
1	7	1	231473-8		DRUCKFEDER	4	COMPRESSION SPRING
1	8	1	457534-8		GLEITPLATTE		SLIDE PLATE
1	9	1	234339-1		DRUCKFEDER	6	COMPRESSION SPRING
1	10	1	454879-5		RASTHEBEL		LOCK LEVER
1	11	1	650744-8		SCHALTER	D3V-16-3C26	SWITCH
1	12	1	231473-8		DRUCKFEDER	4	COMPRESSION SPRING
1	13	1	660417564		SCHALTHEBEL		SWITCH LEVER
1	14	1	632S19-1		KABEL		LEAD UNIT
1	15	1	620E35-1		ELEKTRONIK		CONTROLLER
1	16	1	451814-4		FILZDICHTUNG		DUST GUARD
1	17	1	268254-7		WELLE	6	SHAFT
1	18	1	253715-0		UNTERLAGSCHEIBE	6	FLAT WASHER
1	19	2	268256-3		STIFT	4 INC. 19	PIN
1	20	1	135883-0		STIRNRAD		HELICAL GEAR 47 ASS'Y
1	21	1	161598-3		EXZENTER		CRANK COMPLETE
1	22	1	629945-9		MOTOR	DC	MOTOR
1	23	1	268076-5		WELLE	6	SHAFT
1	24	2	253715-0		UNTERLAGSCHEIBE	6	FLAT WASHER
1	25	1	226831-1		ZAHNRAD	12-31	GEAR
1	26	1	811949-7		TYPENSCHILD	DUM111	NAME PLATE
1	27	1	183G03-2		GEHÄUSE-SET	INC. 3	HOUSING SET COMPLETE
1	27	1	931102-0		6 KANT-MUTTER	M4	HEXAGONAL NUT
1	27	2	263005-3		GUMMISTIFT	6	RUBBER PIN
1	28	6	266429-2		BLECHSCHRAUBE	3x16	TAPPING SCREW
1	29	1	191N23-4		GRASSCHERBLATT	11cm	SHEAR BLADE ASSEMBLY 110 SET
1	29	1	188369-3		FETT-TUBE		GREASE VESSEL SET
1	30	1	140451-6		GEHÄUSEABDECKUNG UNTEN		UNDER COVER
1	E01	1	8030P0-9	ohne Abb., w/o picture	HINWEISSCHILD SCHALLPEGEL	XXDB	SOUND LABEL

A02

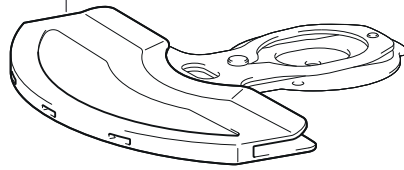

A01
A01-1

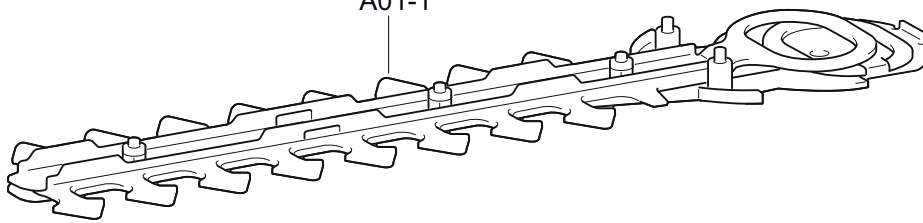

A04

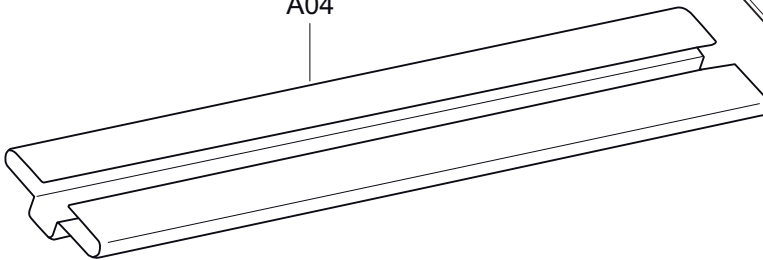

A03

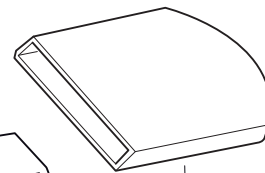

A07
A05

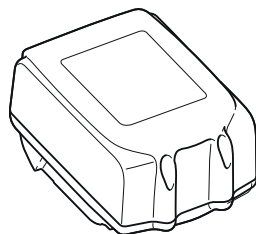

A06

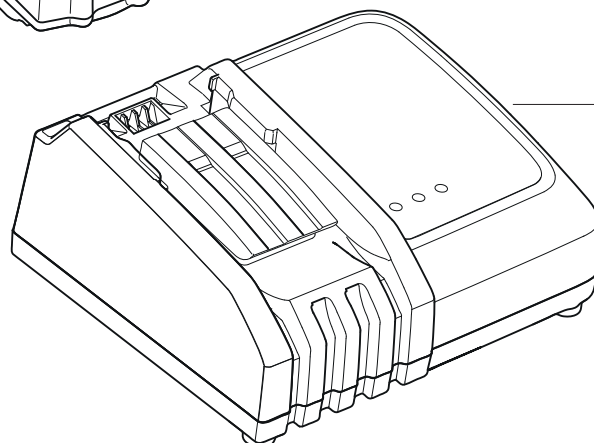



Seite / Page	Pos.	DUM111	Teil-Nr. Part No.	Hinweise Notes	Bezeichnung	Spezifikation Specification	Description
2	A01	1	191N24-2		SCHERBLATT	20cm	SHEAR BLADE ASSEMBLY 200S SET
2	A01 -1	1	188369-3	ohne Abb., w/o picture	FETT-TUBE		GREASE VESSEL SET
2	A02	1	413885-9		AUFBEWAHRUNGSBEHÄLTER	11cm	BLADE COVER 110
2	A03	1	413429-5		SCHERBLATTSCHUTZ GETRIEBESEITE		STORAGE COVER
2	A04	1	458342-0		AUFBEWAHRUNGSBEHÄLTER	20cm	BLADE COVER 200
2	A05	1	450128-8	ohne Abb., w/o picture	KONTAKTSCHUTZKAPPE		BATTERY COVER
2	A06	1	195584-2		LADEGERÄT	DC18RC	FAST CHARGER
2	A07	1	197599-5		AKKU		BATTERY

DUM111



1 DUM111
DUM111

2 Zubehör
Accessories

	Zeichenerklärung	Key to symbols
=> 1999999 2000000 => 2003.04 => TI 2003/07 Acc. = { m Corr.	Produktion bis Serien-Nr. Neues Teil ab Serien-Nr. Neues Teil ab Jahr / Monat Siehe Technische Information Jahr / Nr. Zubehör (nicht im Lieferumfang) Keine Serienausführung, jedoch verwendbar Beinhaltet Positions-Nr. Meterware Druckfehlerberichtigung	Production to serial number New part from serial number New part from Year / Month See Technical Information Year / No. Accessories (not included in the delivery inventory) No standard execution, may be used Contains item number Sold by the meter Error correction
	Änderungen vorbehalten	Specifications subject to change without notice